

Polyguard & Co.

MANUFACTURERS OF QUALITY BURIAL PRODUCTS

North America's Largest
Polymer Burial Vault Manufacturer

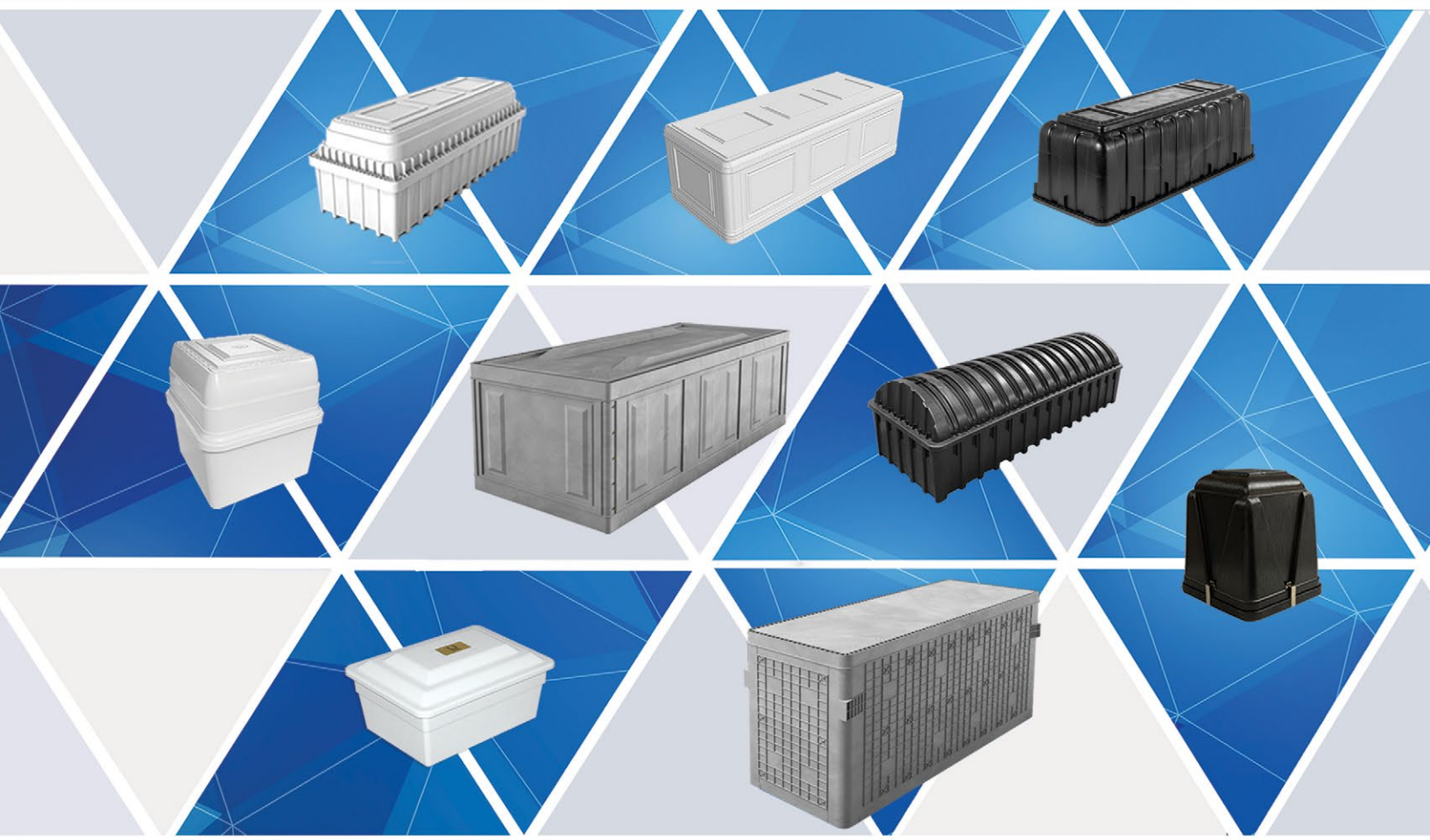

Polyguard Inc 2025 PRODUCT CATALOG



*"Quality is not what happens when what
you do matches your intentions.
It is what happens when what you do
matches your customers' expectations"*

– Guaspari



OVERVIEW

The need for lightweight, durable, water-resistant burial products motivated Polyguard & Co., LLC's creation. Since 1984, Polyguard & Co. has provided North America with some of the finest burial products on the market.

The evolution of Polyguard & Co. has not only set industry standards but also redefined them, consistently delivering manufacturing quality burial products. Over the years, Polyguard & Co. has embraced new technology, always striving for excellence.

We deliver an alternative to traditional concrete vaults by using lightweight, non-biodegradable polypropylene. Millennial polypropylene vaults are a game changer in storage, cost, structural integrity, and overall performance.

Polyguard & Co uses eco-friendly materials to manufacture, which meets or exceeds cemetery requirements while helping to preserve cemetery aesthetics.

Polyguard & Co. is growing with today's technology by engineering state-of-the-art burial products.



SCAN ME



CONTENTS

- ADULT BURIAL VAULTS LIST – 5
 - 6 – 19 Burial Vault Selections
- URN VAULTS LIST – 21
 - 22– 25 Urn Vault Selections
- INFANT / YOUTH PRODUCTS LIST – 27
 - 28 – 29 Infant Casket/Vault Combinations
 - 30 – Infant / Youth Vaults
 - 31 – Majestic Infant / Youth Vaults
- ADDITIONAL CONTENT 32 – 37
 - 32 – Technology is the Core of Polymer Evolution
 - 33 – The Polymer Advantage
 - 34 – Slatwall Miniature Vault Displays
 - 35 – Personalization: Expression of Love
 - 36 – Tools: Set and Display Vaults at the Cemetery
 - 37 – Shipping: Direct to your Location
- MISSION STATEMENT – 38
- CONTACT US – 39



ADULT VAULTS

- Maximus, Assembly (6-7)
- Atlas II, Top Seal (8-9)
- Hercules, Air Seal (10-11)
- Triton Grave Liner (12-13)
- Standard, Air Seal (14-15)
- Maximus Pre-Burial Vaults (16-17)
(Double & Single Units)
- Oversized/Oversized XL (18-19)
(Standard Size & Custom)



Polyguard & Co.
 MANUFACTURERS OF QUALITY BURIAL PRODUCTS

800-654-1067

North America's Largest
 Polymer Burial Vault Manufacturer

MAXIMUS ADULT BURIAL VAULT



STATE-OF-THE-ART PATENTED BURIAL VAULT

- The Maximus state-of-the-art burial vault is engineered and constructed with a six-panel patented assembly construction.
- The Maximus ships flat and stacks efficiently one on top of the other to provide maximum storage space.
- The Maximus Burial Vault provides the ultimate graveside presentation, and has superior cemetery grounds integrity.
- The Maximus is a game changer when it comes to transport, storage, ease of handling, load-bearing capacity, ease of assembly and versatility.

MAXIMUS ADULT BURIAL VAULT

Features:

- When compared to concrete the light-weight Maximus provides versatility.
- It's aesthetically pleasing with a patented six-panel assembly engineered for strength.
- Three carapace frames on the lid provide an option for personalization (17"Lx11"H).
- The lid structure has 20 vertical ribs and 60 horizontal ribs, with each cell depth at 2.75" and 1.33" on-center.
- The Maximus offers exceptional presentation at the graveside, but also provides peace of mind for the vault contents, and cemetery grounds integrity.
- Each unit comes with screws for the assembly of the base-to-side panels.
- The inside end panels have ten vertical ribs and eight horizontal ribs. Inside the sidewall panels have 26 vertical Ribs and 8 horizontal ribs.
- Lid-to-box fit seamlessly with easy tongue-in-groove closure.

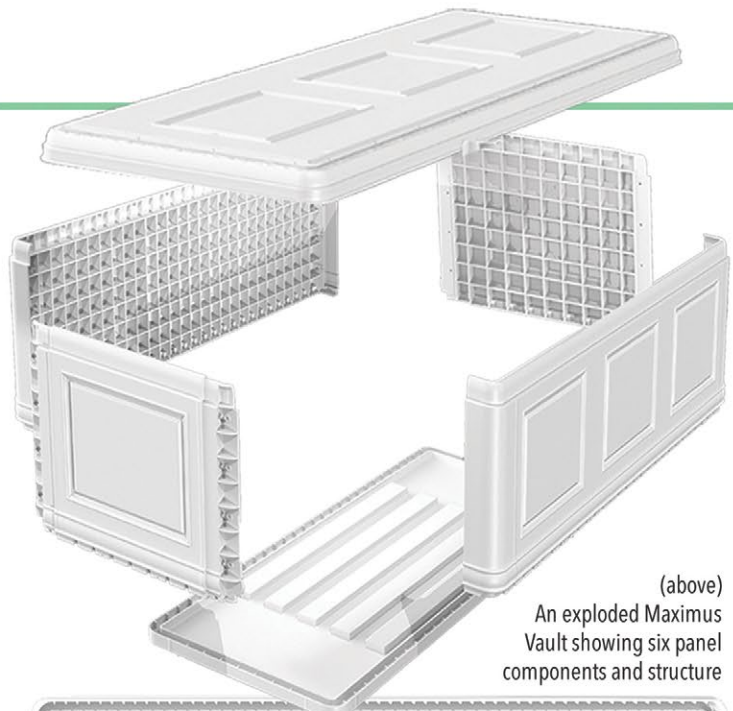

(above)
An exploded Maximus Vault showing six panel components and structure

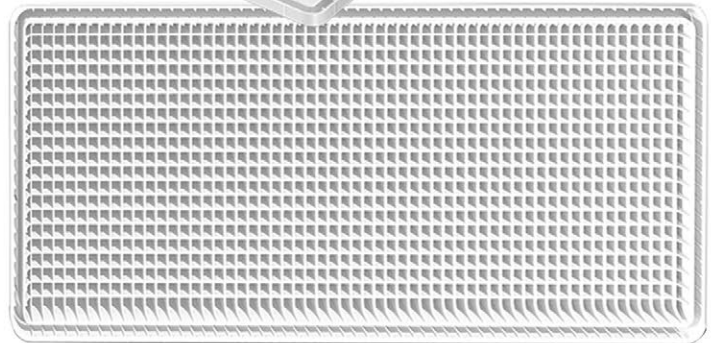

(above) The Maximus lid cell structure is engineered for superior strength
(below) Deep set tongue-in-groove closure



Dimensions:

Exterior: 90Lx34.56Wx29.12H

Interior: 85.75Lx30.25Wx24.5H

Personalization Option

Weight: 220 lbs assembled

White Polymer



Personalization option: handwritten directly to the lid surface using fine-tip markers. Easy graveside setup shows the lid displayed for a "Final Expression of Love" – photos and handwritten sentiments options

ATLAS II ADULT BURIAL VAULT



Graveside display shows the Atlas lid placed on custom stands available at Polyguard & Co.



PRECISION ENGINEERED

TECHNOLOGY & ENGINEERING MEET TO CREATE WORLD CLASS VAULT

- The Atlas II provides the burial industry with an alternative to concrete, and meets or exceeds industry standards and cemetery requirements.
- The Atlas II is engineered for safety, protection, longevity, performance, and peace of mind
- Constructed of polypropylene, the Atlas II is referred to as the Millennial Polymer because of its impervious molecular structure.
- As new technology and engineering are made available, Polyguard continues to revolutionize the the burial industry with high tech polymer products.

ATLAS II ADULT BURIAL VAULT

Features

- A seamless molecular structure offers ultimate protection while helping to preserve the cemetery grounds and aesthetics.
- Certified strength tested to withstand 12,100 lbs of downward pressure.
- Protects against moisture with non-porous, non-biodegradable polypropylene.
- A seamless lid-to-box fit is easy to execute with a deep seated tongue-in-groove closure.
- Engineered with 48 cross-ribs and 12 counter rib supports with numerous right angles.
- Consistent .250 wall thickness and numerous 90° corners for engineered strength.
- Three carapace frames on the lid provide an option for personalization. (frames: 11"x17")
- The Atlas II is a premium burial vault with perfect features to meet families expectations and exceed cemetery requirements.
- Engineered with vertical gussets surrounding the lower section of the lid, which facilitates a net-zero sidewall expansion and shifting.

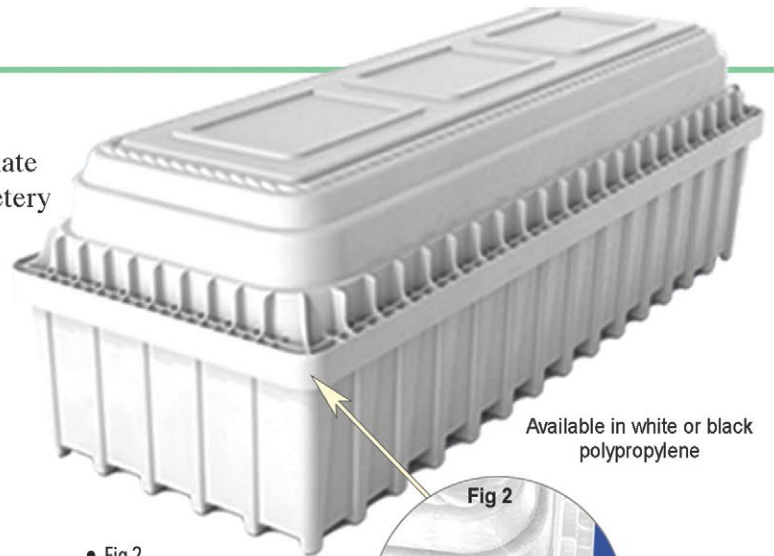

Available in white or black polypropylene

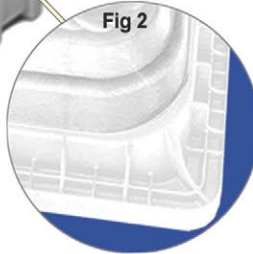

- Fig 2 Birds-eye-view from the top of the lid showing vertical gussets set into a cell structure

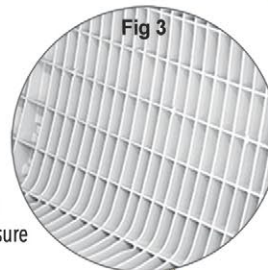

- Fig 3 Engineered lid ribbing and counter rib support

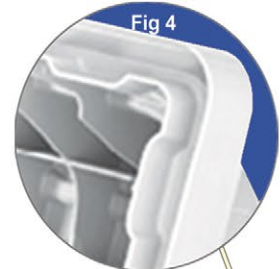

- Fig 4 Deep-set lid-to-box tongue-in-groove closure

- Fig 5 Mastic sealant provides a secure lid-to-box seal

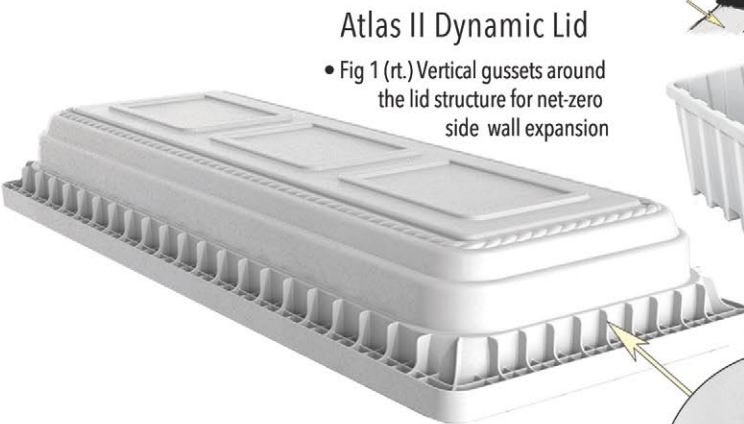
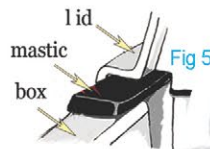

Atlas II Dynamic Lid

- Fig 1 (rt.) Vertical gussets around the lid structure for net-zero side wall expansion

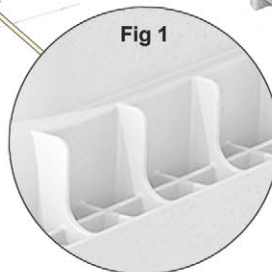

- Engineered with 36 vertical box reinforcement structures

Dimensions:

Exterior: 91Lx35.25Wx30H
 Narrow Interior: 85Lx30Wx25H
 Wide Interior: 86.5Lx31.5Wx25H

Lid: 81 lbs • Box: 62 lbs
 Total: 143 lbs

HERCULES ADULT BURIAL VAULT

Available in black
or white
polypropylene



PRECISION ENGINEERED

THE HERCULES DOME AND BASE IS OUR PREMIER AIR SEAL ADULT VAULT

- The Hercules provides the burial industry with an alternative to concrete and meets or exceeds industry standards and cemetery requirements.
- The Hercules can be used as a sealed or unsealed unit, or as a dome only, and is available in white or black polypropylene.
- Engineered with 64 cross-ribbing structural supports and 7 counter cross-ribbing supports.
- Carapace frames for personalization

HERCULES ADULT BURIAL VAULT

Air Seal Dome and Base

Features

- Engineered with a 180° reinforced channeled edge for additional strength.
- Engineered using high density, water-resistant, non-porous, and non-biodegradable polypropylene.
- Certified load bearing capacity meets and exceeds industry and cemetery requirements.
- For decades, our burial vaults have revolutionized the burial industry with space age polymer products that have been tested to be as strong as concrete.
- Unlike typical concrete vaults, Hercules protects against moisture intake.
- Compression strength tested to 8,900 lbs. (Our testing results are available from a third party certified product testing company.)
- Consistent .250 wall thickness and numerous 90° corners for structural strength.



- Fig 1 (rt.) Series of engineered wall pillars designed with deep set right angles and repeating supports

- Fig 2 (rt.) Dome engineered with 64 cross-ribbing structural supports and 7 counter cross-ribbing supports

- Fig 3 Air seal design protects against water rising inside

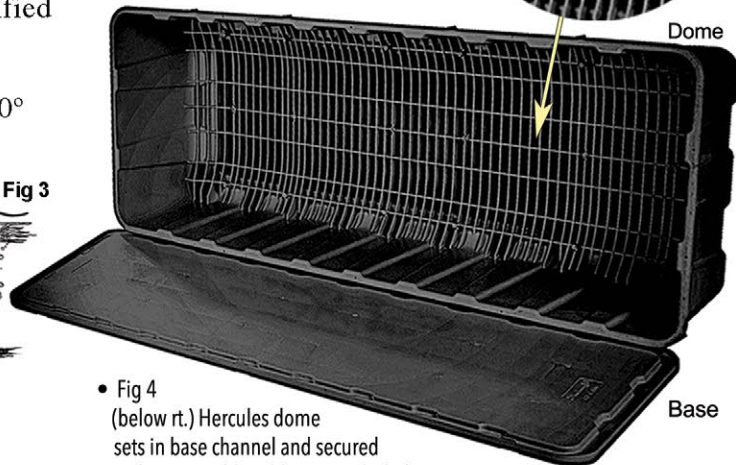
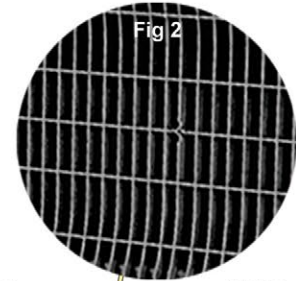

- Fig 4 (below rt.) Hercules dome sets in base channel and secured with irreversible cable ties: included (sealant available)

Dimensions:

Exterior: 90Lx35Wx29.5H
 Narrow Interior: 85Lx29Wx25D
 Wide Interior: 87.5Lx31.5Wx25H
 Base: 91Lx35.5Wx3H

Personalization on Lid:
 Sides: 8.125Wx13.75H
 Center: 42.125Wx13.75H
 Dome: 102 lbs • Base: 34 lbs
 Total : 136 lbs



Ten Pre-Drilled Cable Hole Locations

Pre-drilled holes are distributed around the bottom of the dome and base. Cable ties provide another way to secure the Hercules Dome to its Base.



Cable ties are made of heavy polymer and are easy to secure. Place the Dome on the base, align at one corner, and work your way around the base.

TRITON GRAVE LINER

Non-Protective



Available in
black polypropylene

NON-PROTECTIVE GRAVE LINER



PRECISION ENGINEERED

- The Triton Grave Liner is molded after the arch shaped design often used in the architectural industry to bear greater loads.
- The Triton Grave Liner is lightweight and easy to handle without compromising strength.
- The Triton Grave Liner is a non-protective vault molded from polypropylene with a certified 11,000 lb load bearing capacity.
- The Triton Grave Liner is eco-friendly and constructed from recycled post industrial composites.
- The Triton Grave Liner protects the cemetery aesthetics and defines the grave space.
- The Triton Grave Liner has (4) 1/2" holes in the base.

TRITON GRAVE LINER

Features

- The Triton Grave Liner is a structurally sound, non-protective grave liner molded from polypropylene material that is foam injected.
 - The Triton Grave Liner is certified at an 11,000 lb load bearing capacity to meet and exceed cemetery requirements.
- *In a class of its own* —
- The Triton's arch shape lid design bears greater loads underground.
 - Engineered and manufactured using State-of-the-art molds and equipment.
 - The Triton Grave Liner is easy to handle and join box and lid seamlessly with ease.
 - The Triton Grave Liner is manufactured with recycled post industrial composites.
 - When it comes to value and functionality, it will be hard to find a suitable comparison to the Triton Grave Liner.

Dimensions:

Exterior: 90.75Lx34.25Wx27.25H

Interior Wide: 86.5Lx31.5Wx25H

Narrow Interior: 85Lx28.5Wx25H

Certified load bearing capacity
11,000 lbs

Lid: 51 lbs, Box: 61 lbs
Total: 112 lbs



- Fig 1
Triton Grave Liner is engineered using a system of right angles and deep set ribbing and counter-ribbing with an engineered arch bridge lid design for strength

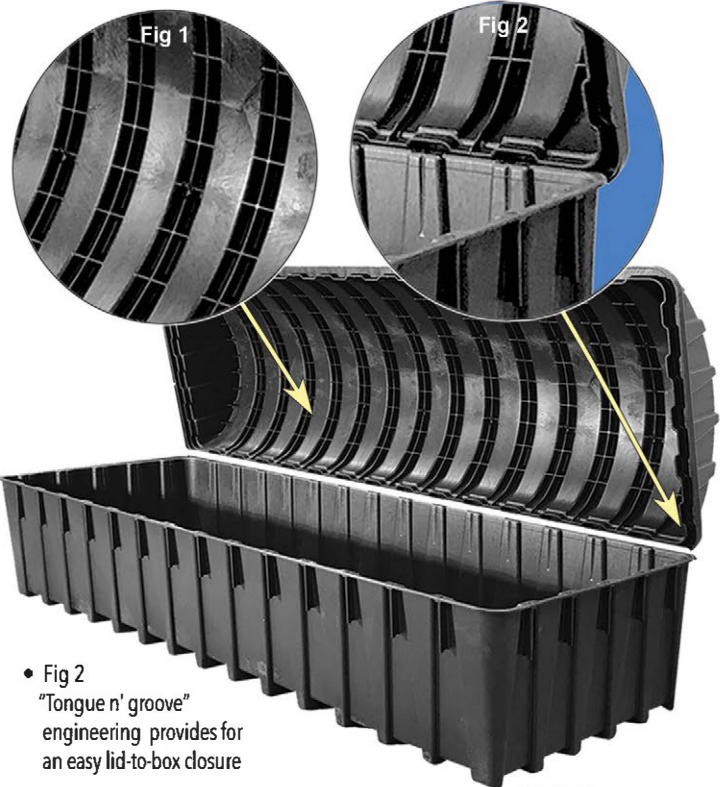

- Fig 2
"Tongue n' groove" engineering provides for an easy lid-to-box closure

- Fig 3
The Triton Grave Liner is foam injected with non-porous, high-density, environmentally safe non-biodegradable polypropylene

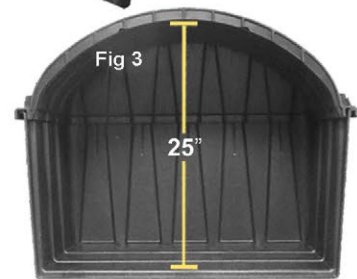

- Fig 4
This non-protective grave liner has four 1/2" holes in corners of box floor.

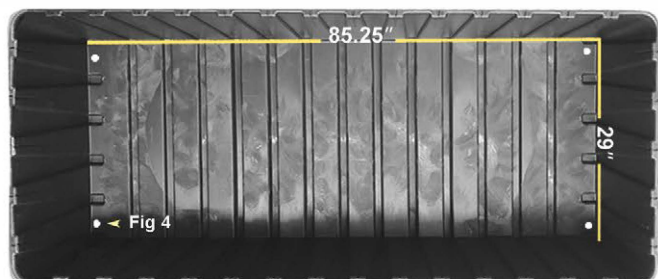

Profile view of the Triton Grave Liner



STANDARD ADULT BURIAL VAULT



Available in
black polypropylene



Dome
Personalization Area:
72.25Lx14.5W



PRECISION ENGINEERED

STANDARD AIR SEAL ADULT BURIAL VAULT

- The Standard Burial Vault is molded from high-density, non-biodegradable polypropylene.
- The Standard Burial Vault interior has a deep-set support ribbing inside the top of the dome for maximum strength.
- The Standard Burial Vault walls have multiple vertical right-angle pillar supports, which provide superior strength.
- The Standard Burial Vault air seal design captures air inside the dome, which will inhibit groundwater from rising in the vault.
- Constructed of non-porous space-age polymer, the Standard Burial Vault is non-biodegradable.

STANDARD ADULT BURIAL VAULT

Features

- Engineered using high-density, water-resistant, non-porous, and non-biodegradable polypropylene.
- The dome side walls are engineered with multiple right angles and 180° reinforced channeled edge.
- Certified load-bearing capacity to meet and exceed industry and cemetery requirements with a downward pressure capacity of 5,000 lbs per sq. ft.
- The Standard Burial Vault interior has a deep set support ribbing inside the top of the dome for maximum strength.
- Seamless construction rolled edges and deep set tongue-in-groove for an easy dome-to-base closure
- Our Standard air seal vault works to naturally capture air to keep water from rising inside.

Dimensions:

Exterior: 95Lx36Wx31H
 Interior Wide: 91Lx31.5Wx23.5H
 Interior Narrow: 91Lx29Wx23.5H
 Personalization on Top of the Dome:
 72.25Lx14.5W

Base 26 lbs • Dome 102 lbs
 Total 128 lb

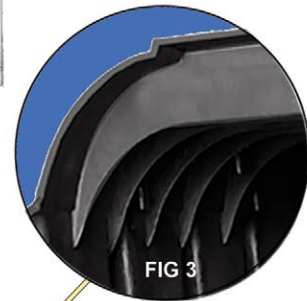

- Fig 1 Series of exterior wall pillars with deep set right angles
- Fig 2 Stainless steel clip lock System attaches the dome-to-base: clips are included
- Fig 3 Dome has extra deep set ribbing
- Fig 4 Air seal design protects against water rising inside



Air seal concept

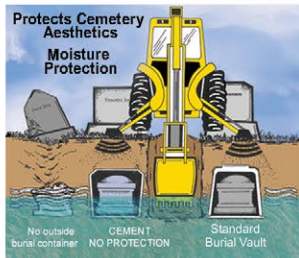
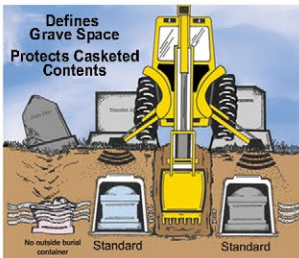

Standard Adult Vault protects cemetery surface aesthetics while providing moisture protection through the air seal design concept

DOUBLE AND SINGLE MAXIMUS PRE-BURIAL VAULTS



PRECISION ENGINEERED



Double Dimensions:
Interior: 85.75Lx30.25Wx51H
Exterior: 90.06Lx34.56Wx55.53H



Single Dimensions:
Interior: 85.75Lx30.25Wx25H
Exterior: 90.06Lx34.56Wx32H

PRE-BURIAL VAULT INNOVATION

- Each detail established during the design and engineering of the Maximus Pre-Burial Vault is key to providing the planet's most cost efficient, innovative, and installation friendly product for pre-burial projects.
- Maximus Pre-Burial vaults are manufactured using a combination of light-weight polymer and polymer-coated industrial strength steel. Our pre-burial vaults are engineered for easy use, strength, longevity, and peace of mind.



MAXIMUS PRE-BURIAL VAULTS

Features

- The Maximus Pre-Burial Vaults are engineered for versatility and can be assembled on location for a family cemetery plot, or as a cemetery expansion project.
- A steel-reinforced lid is built to withstand below-ground pressures during and after installation, as well as future burial disruptions
- The Maximus Double Pre-Burial Vault meets the specifications of a pre-interment project and can be easily stored until installation.
- The Maximus Pre-Burial Vaults can be assembled onsite and can be easily moved around and aligned by a lift operator and a person on the ground.
- The Maximus Pre-Burial Vaults bring burial advantages, which are not available with traditional concrete. It can be stored flat and assembled later. The lid can be lifted using cables with supports molded at each corner of the lid.
- The Maximus Pre-Burial Vaults bring burial advantages, which are not available with traditional concrete. It can be stored flat and assembled later. The lid can be lifted using cables with supports molded at each corner of the lid.
- Ten # 8, 3/4" steel rebar system in the lid.

• Fig 1 (below) Molded lid claws at each corner make for easy lid handling or second level interment.

• Fig 2 (below rt.) Sidewall corner slings make for easy vault positioning.

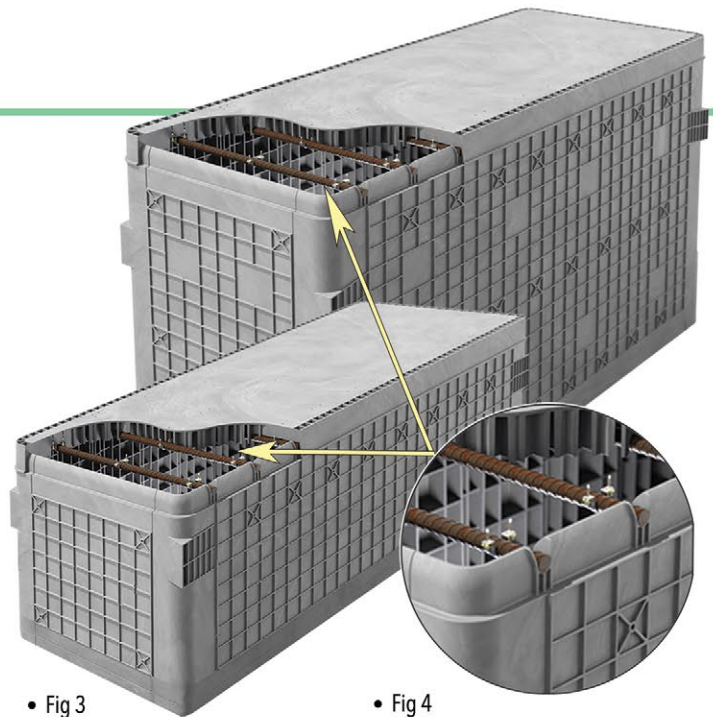
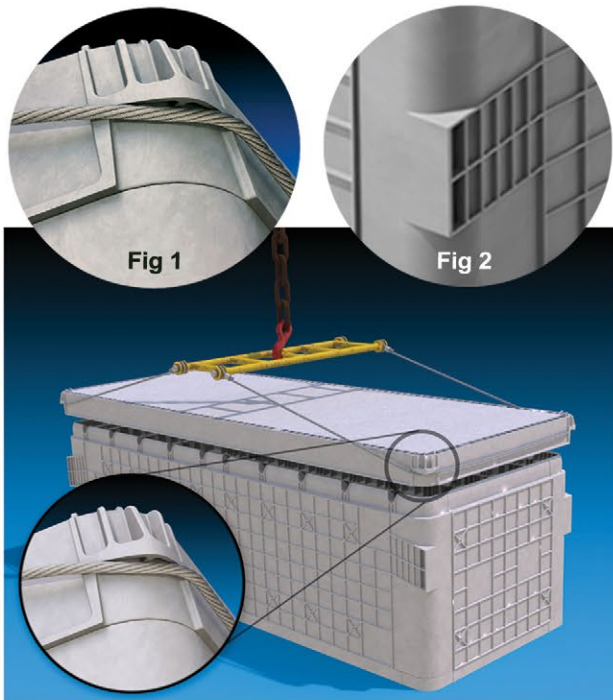

• Fig 3 (below) Rebar support channels house 10-1" rebar on the underside of the lid

• Fig 4 (above) The cut-out shows rebar under the lid and resting down in the sidewall saddles

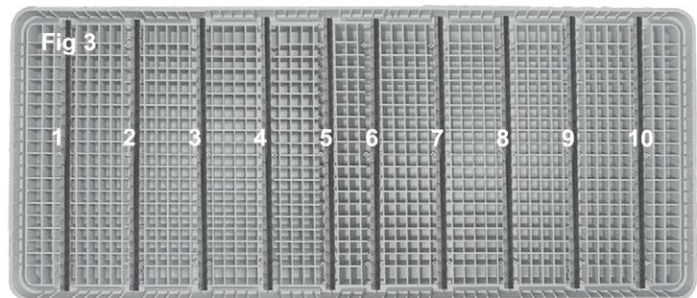

• Fig 5 (below) Platform (A/B) are temporarily removed for 1st interment

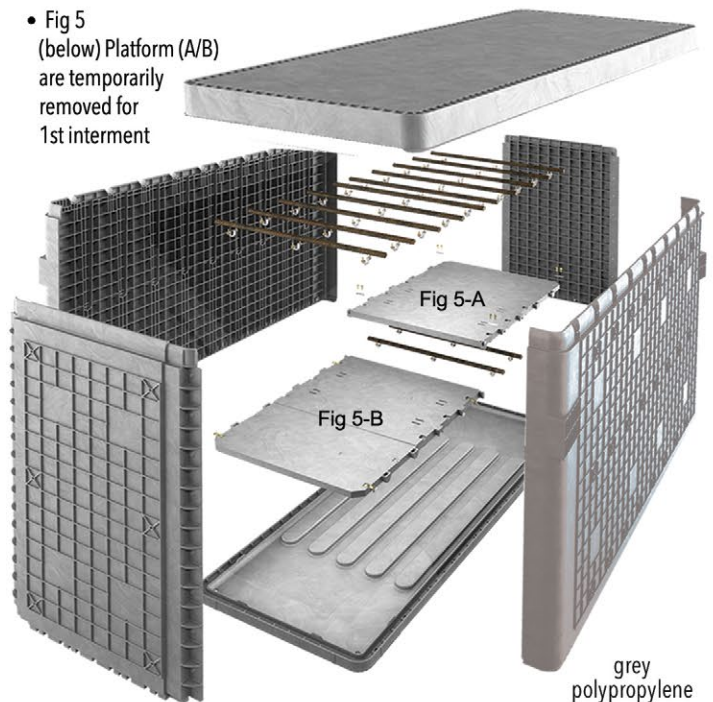

OVERSIZED BURIAL VAULTS



(above) Two Oversized Burial Vaults are converted at the factory to build one Oversized XL Custom Burial Vault.

THE OVERSIZED VAULT AND THE OVERSIZED XL CUSTOM

- The Oversized Burial Vault (Fig.1) provides the burial industry's need for a larger size vault. It accommodates casket widths up to 36" and is engineered for polymer-coated steel rebar in the lid.
- The Oversized Burial Vault (Fig.1) is stored flat, easily transported, and versatile for on location assembly.
- The Oversized XL Custom Burial Vault (Fig.2) utilizes the Oversized Vault components and adds polymer-coated steel rebar to the lid, base, and end panels for superior strength.
- The Oversized XL Custom Burial Vault (Fig.2) is built-to-order at the factory using two Polyguard Oversized Burial Vaults.
- The Oversized XL Custom Burial Vault size option range includes: 40", 44", 48", and 52" widths.

VAULT SOLUTIONS FOR LARGER CASKET SIZES

POLYGUARD'S OVERSIZED BURIAL VAULT

Features

- The Oversized is strength tested to 15,000 lbs of downward pressure.
- The Polyguard Oversized Burial Vault is designed to accommodate eight 1" steel rebar lid supports and is assembled with twenty corner bolts.
- The Oversized Polyguard Vault is engineered with interior cross-ribs and counter ribbing supports. The exterior walls also have deep vertically embossed panels which provide superior overall strength.
- The Oversized provides peace of mind while preserving the cemetery aesthetics.

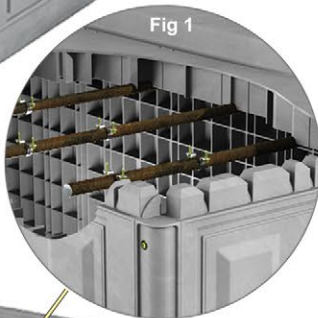

- Fig 1
A cut-away-view shows a section of the interior side-wall cell structure, the depth of the lid structure, and the location of the steel rebar supports.

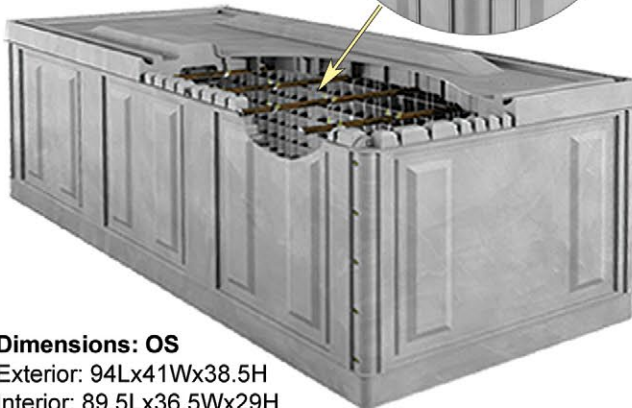

Dimensions: OS
Exterior: 94Lx41Wx38.5H
Interior: 89.5Lx36.5Wx29H

Dimensions: OS XL
Exterior: 94Lx41Wx38.5H
Interior: 89.5Lx36.5 up to 52Wx29H

POLYGUARD'S OVERSIZED XL CUSTOM BURIAL VAULT

Features

- The Oversized XL is custom assembled at the factory using two standard Oversized vaults.
- Structural expansion accommodates: casket sizes over 36", 40", 44", 48", and 52".
- The Oversized XL is molded from non-porous and non-biodegradable polypropylene.
- Consistent .250 wall thickness and numerous 90° molded corners along the end and side walls.
- Polypropylene is referred to as the Millennial Polymer because of its impervious molecular structure.

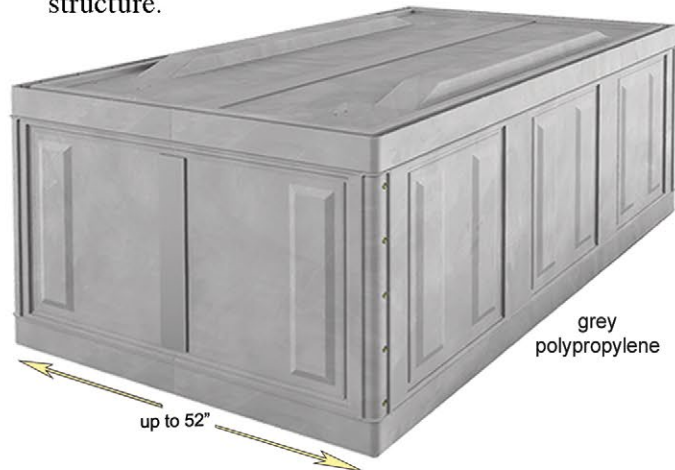

- (above) Rebar graphic shows the locations of #8, 1" steel rebar rods on the interior of the Oversized XL Custom Vault.

- Fig 2) 5 Rods seated with clamps undersided lid
- Fig 3) 5 Rods seated with clamps in the base
- Fig 4) 3 Rods seated in each end panel

*"Every great dream begins with a dreamer.
Always remember, you have within you the strength,
the patience, and the passion to reach for the stars
to change the world"*

– Harriet Tubman

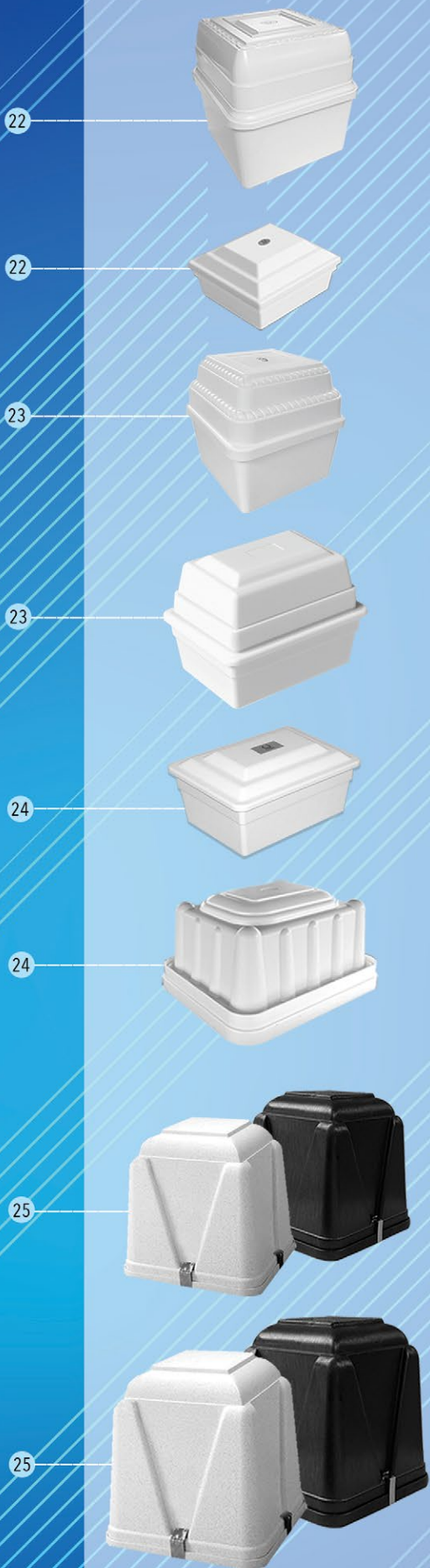

URN VAULTS

- Athena (22)
- Ella Cremains (22)
- Luxor (23)
- Olympia Double (23)
- Olympia Horizontal (24)
- Roman Poly (24)
- Standard Medium (25)
White or Black
- Standard Large (25)
White or Black



Polyguard & Co.
MANUFACTURERS OF QUALITY BURIAL PRODUCTS

800-654-1067

North America's Largest
Polymer Burial Vault Manufacturer

ATHENA URN VAULT



- The Athena Urn Vault size, design, and elegant glossy finish makes it a popular choice for graveside display; option for personalization on top of the lid.
- The Athena Urn Vault is made of high-density polyethylene, which is notably used for underground barriers.
- The Athena Urn Vault network of ribbing in the lid provides added strength and durability to the lid and box structure.
- The Athena Urn Vault is strength tested and has become a preferred choice of cemeteries.

**Dimensions:
Athena Urn Vault**

Inside
12Lx12Wx14H
Outside
16.84x16.84x15.5
Lid
Personalization
5.25x5.25
Weight 12 lbs



ELLA CREMAINS URN VAULT



- The Ella Cremaims Urn Vault is our smallest urn vault and is mold-injected using high-density ABS polymer.
- The Ella Cremaims Urn Vault lid has ribbing supports with deep-set tongue-in-groove closure.
- The Ella Urn Vault meets cemetery requirements, and due to its compact size it helps to preserve precious space in cremation gardens.
- The Ella Cremaims Urn Vault is used with the temporary urn offered to families by most crematoriums.



typically
holds a standard
ash box

**Dimensions:
Ella Cremaims
Urn Vault**

Inside Wide:
9.5Lx8Wx5H
Inside Narrow:
6Lx4.25Wx6H
Outside:
11.75Lx10Wx6.5H
Weight 3 lbs



LUXOR
URN VAULT



- The Luxor Urn Vault is a protective urn vault made of industrial-grade polymer.
- The Luxor Urn Vault has an ultra smooth exterior and matte-finish.
- The Luxor Urn Vault is precision engineered with an aesthetically pleasing rope-motif encircling each tier level.
- The Luxor Urn Vault comes with silicone sealant for peace of mind.

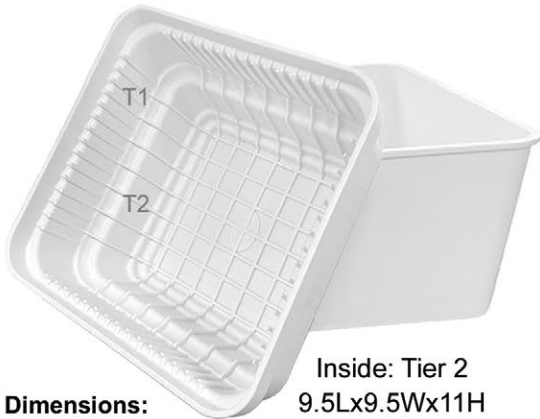

Dimensions:
Luxor Urn Vault

Inside: Tier 1
10.5Lx10.5Wx8.5H

Inside: Tier 2
9.5Lx9.5Wx11H
Outside:
14Lx14Wx12.75H
Weight 11 lbs

OLYMPIA DOUBLE
URN VAULT



- The Olympia Double Urn Vault is lightweight, yet durable and comes with a silicon sealant for a permanent seal.
- This Olympia Double Urn Vault is a top-seal vault with injection molded lid and box.
- The Olympia Double Urn Vault lid height provides versatility by accommodating taller urns or two common sized urns.
- The Olympia Double Urn Vault lid is interchangeable with the Olympia Horizontal Urn Vault box (see pg. 24).



Dimensions:
Olympia Double Urn Vault

Inside Wide- Tier 1
15Lx10.25Wx9H
Inside Narrow- Tier 2
13.25Lx8.5Wx13.75H

Inside Narrowest-Tier 3
10Lx5.25Wx15.125H
Outside:
18.5Lx13.5Wx16H
Weight 10 lbs

OLYMPIA HORIZONTAL URN VAULT



Structural ribbing in the lid for added strength
Olympia Double lid (pg 23) also fits the Olympia Horizontal box

- The Olympia Urn Vault is made of light-weight high-density polystyrene.
- The Olympia Urn Vault is protective, water resistant, non-biodegradable, and sealed with a silicone sealant for permanence and peace of mind.
- The Olympia Urn Vault has a network of ribbing and counter-ribbing in the lid for superior strength.
- The Olympia Urn Vault is a popular urn vault widely used throughout North America and beyond.



Dimensions: Olympia Urn Vault

Inside Wide:
14Lx9Wx8.75H

Inside Narrow:
10.25Lx5Wx9.75H

Outside:
18.5Lx13.5Wx10H

Weight 8 lbs



ROMAN POLY URN VAULT



- The Roman Urn Vault is made of high-quality, high-density, water-resistant, non-biodegradable polypropylene .
- The Roman Urn Vault dome is engineered with vertical corner support pillars and ten sidewall pillars.
- The Roman Urn Vault is an air-seal dome-to-base design with many right angles and arched surfaces, which compliments its superior strength.
- The Roman Urn Vault structural ribbing and cross-ribbing in the lid provide additional engineered support.
- The Roman Urn Vault has an extra deep tongue-in-groove closure.

Base and Dome:
engineered for maximum
strength



Dimensions: Roman Urn Vault

Inside Wide:
14Lx11Wx9H

Inside Narrow:
10.25Lx7.25Wx11H

Outside:
19.75Lx16.75Wx11.5H

Weight: 14 lbs



STANDARD MEDIUM 14" URN VAULT



Available in Black or White
Polypropylene

- The Standard Medium Urn Vault is a ‘standard’ in the burial industry marked by its exceptional strength and durability and versatility.
- The Standard Medium Urn Vault is engineered using a deep right-angle “V” shape structure on all four side-walls and wide rounded exterior corners.
- The Standard Medium Urn Vault dome-to-base design has a deep-set tongue-in-groove closure, and is secured with four stainless steel clips.

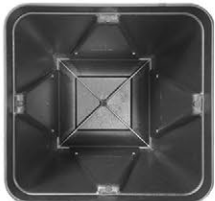

Interior dome structure



base structure; underside

Dome to
base steel clips
included



Dimensions: Standard Medium Urn Vault

Inside Narrow
10Lx10Wx10H
Inside Wide
11.25Lx11.25Wx7.5H
Outside
14Lx14Wx14.5H
Lid
Personalization
5.25Lx5.25W
Weight 7 lbs



STANDARD LARGE 18" URN VAULT



- The Standard Large Urn Vault is a larger version of the Standard Medium with an impressive 18” exterior height and width. It too has been marked by its exceptional strength and overall durability.
- The Standard Large Urn Vault accommodates a variety of larger and taller urn sizes.
- The Standard Large Urn Vault dome-to-base design has a deep-set tongue-in-groove closure, a deep “V” shape right-angle sidewalls and is secured with four heavy stainless steel clips.



Dimensions: Standard Large Urn Vault

Lid
Personalization
8.75Lx8.75W
Inside Narrow:
12.25Lx12.25Wx14.75H

Inside Wide:
13.5Lx13.5Wx13.5H
Outside:
18.5Lx18.5Wx18.625H
Weight 15 lbs

"Quality is never an accident; it is always the result of high intention, sincere effort, intelligent direction and skillful execution; it represents the wise choice of many alternatives"

– William A. Foster

28



29



29



30



30



30



31



31



31



INFANT & YOUTH

- TLC Small Casket/Vault Combo (28)
- TLC Med. Casket/Vault Combo (29)
- TLC Large Casket/Vault Combo (29)

- TLC Small Infant Vault (30)
- TLC Med. Infant Vault (30)
- TLC Large Infant Vault (30)

- Majestic Small Infant/Youth Vault (31)
- Majestic Med. Infant/Youth Vault (31)
- Majestic Large Youth Vault. (31)



Polyguard & Co.
MANUFACTURERS OF QUALITY BURIAL PRODUCTS

800-654-1067

North America's Largest
Polymer Burial Vault Manufacturer



INFANT CASKET/VAULT COMBINATION



24"/SM



Casket

A high-gloss hardwood casket is finished in rich, warm tones and lined with a soft crepe with white lace accents. The Tender Loving Care theme is reflected in the head panel with a silver embroidered heart.

Vault

The vault is made of industrial-grade ABS polymer. The protective vaults are water resistant, non-biodegradable, and sealed with a mastic sealant for permanence and peace of mind.

Each vault has a rope motif encircling the outer edge. The top of the vault has a center frame space for personalization.

The heart design seen on the casket head panel is replicated on the vault. The heart motif represents the tender loving care that goes into each casket/vault Combination.

Dimensions:

- Small Casket Dimensions
Outside: 24Lx12Wx11.5H
Inside: 20Lx7.5Wx7H
- Small Air Seal Vault Dimensions
Outside: 30Lx18.5Wx14H
- Mastic sealant is provided

TLC
TENDER LOVING CARE
SMALL COMBO



INFANT CASKET/VAULT COMBINATION

Caskets

The medium and large TLC caskets are beautifully crafted with rich hardwood, high-gloss finish, and lined crepe material, and lace borders. The Tender Loving Care theme reflects in the head panel with a silver embroidered heart.

Vaults

The vault for the medium and large TLC caskets has industrial-grade ABS thermo-formed polymer. The protective vaults are water-resistant, non-biodegradable, and come with mastic sealant for permanence and peace of mind. The medium vault has a rope motif and heart stickers on each side of the center frame.

The large TLC Vault is an identical replica of the medium vault, and manufactured to accommodate the large TLC Casket.

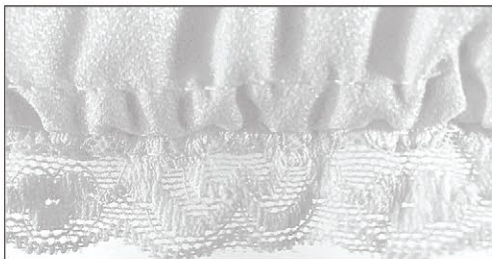

Dimensions:

- Medium Casket
Outside: 30Lx12Wx11H
Inside: 27Lx 8.5Wx7H
- Medium Top Seal Vault
Outside: 34.75Lx19.5Wx13.25H
- Large Casket
Outside: 37Lx14Wx14.25H
Inside: 33.5Lx10.5Wx8.5H
- Large Top Seal Vault
Outside: 40.25Lx19.5Wx16.75H
- Mastic sealant is provided





TENDER LOVING CARE INFANT VAULTS



Small TLC Vault

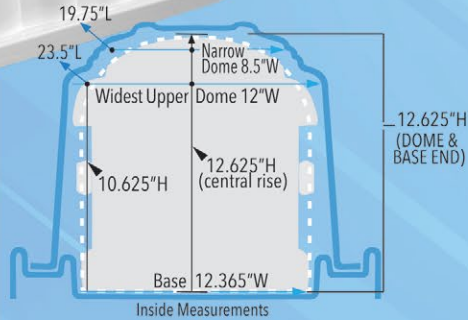

Medium TLC Vault

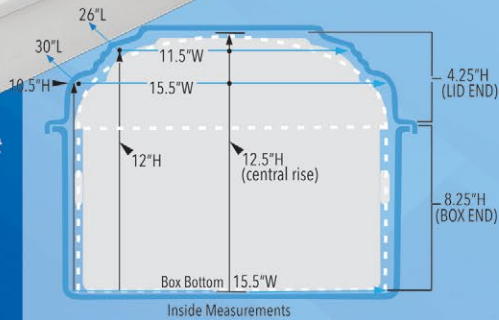

Large TLC Vault

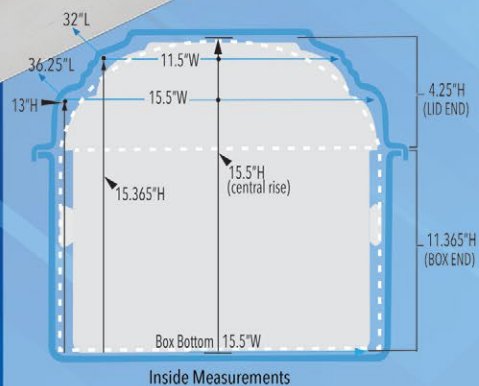

- Mastic Sealant included with all TLC Vaults

INFANT VAULTS

Small TLC Air-Seal Vault

The small TLC Infant Vault is made of industrial-grade ABS polymer and is water-resistance and non-biodegradable. The vault can be sealed with a mastic sealant for permanence and peace of mind.

The small TLC Infant Vault is an air-seal design and is thermo-molded and engineered with pillars around the circumference for strength and aesthetics. The lid features a rope design and "stepping" for engineered strength.

Dimensions:

- Outside: 31Lx19.25Wx14H
- Inside Wide: 23.5Lx12.365Wx10.625H
- Inside Narrow: 19.75Lx8.5Wx11.75H

Medium TLC Top-Seal Vault

The medium TLC Infant Vault is made of industrial-grade ABS polymer and is water-resistance and non-biodegradable. The vault can be sealed with a mastic sealant for permanence and peace of mind.

The TLC Medium Vault is a top-seal design and is thermo-molded and engineered with a stair-step lid for additional strength. The lid also features a rope design with two oval heart decal emblems.

Dimensions:

- Outside: 34.75Lx19.5Wx13.365H
- Inside Wide: 30Lx15.75Wx10.5H
- Inside Narrow: 26Lx11.875Wx12H

Large TLC Top-Seal Vault

The large TLC Infant Vault is made of industrial-grade ABS polymer and is water-resistance and non-biodegradable. The vault can be sealed with a mastic sealant for permanence and peace of mind. It is a larger replica of the medium TLC Vault.

Dimensions:

- Outside: 40.25Lx19.25Wx16.75H
- Inside Wide: 35.75Lx15.5Wx13H
- Inside Narrow: 32Lx11.5Wx15.5H

* Diagrams indicate inside end profile measurements for each TLC Infant Vault size. The interior profile measurements provided are to assist with custom or infant casket sizes.

For additional details or questions please call and speak with a customer service representative: 800-654-1067

INFANT/YOUTH VAULTS

Majestic Air-Seal Ribbed Vaults

The Majestic Top Seal Infant Vault Series are available in three sizes. All vaults are structurally strong, impervious to water, and can be sealed with mastic sealant for a permanent seal.

These high density polymer vaults are an economical alternative to concrete grave-liners while providing a water resistant environment for the casket.

The Majestic Top Seal Infant and Youth Burial Vaults have an engineered ribbing structure which provides added strength.

Dimensions:

Small Top Seal Holds 2'6" Casket

Outside: 43Lx23.5Wx18H
 Inside: 37Lx18Wx15.5H
 Inside Narrow: 37Lx8.5Wx15.5H

Medium Top Seal Holds 3'6" Casket

Outside: 54.75Lx28.5Wx20H
 Inside: 50Lx23.25Wx18H
 Inside Narrow: 50Lx11.5Wx18H

Large Top Seal Holds 4'6" Casket

Outside: 67.75Lx30Wx20.25H
 Inside: 61.5Lx23.25Wx18.5H
 Inside Narrow 61.5Lx11.5Wx18.5H

Note: The Majestic Series is designed to fit: 2'6", 3'6", and 4'6" standard caskets.*

- Mastic Sealant is included with all Majestic Vaults



Small Majestic Vault



Medium Majestic Vault



Large Majestic Vault

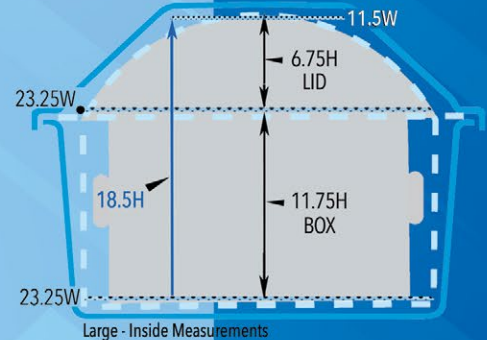
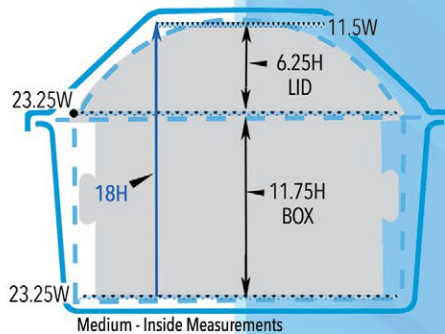
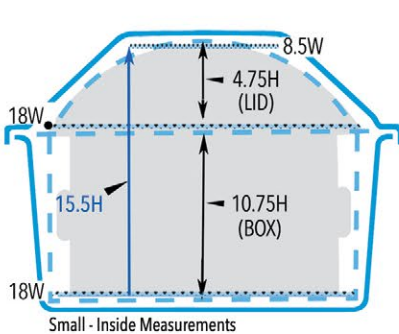

* Diagrams indicate end profile measurements only. The interior end profile measurements are provided to assist with a custom casket fit. The Majestic Series is designed to fit: 2'6", 3'6", and 4'6" standard wood and metal caskets.

For additional details or questions please call and speak with a customer service representative: 800-654-1067



TECHNOLOGY IS THE CORE OF POLYMER EVOLUTION

Polyguard & Co. Utilizes Millennial Polymer to Manufacture New-Age Products

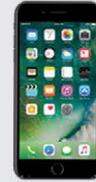

Concrete Vault

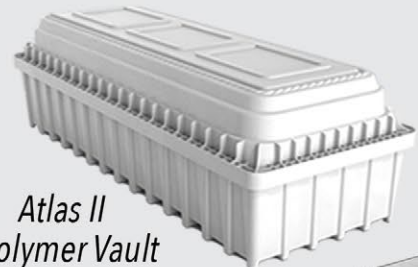

*Atlas II
Polymer Vault*



Maximus, Assembly



Triton Grave Liner



Hercules, Air Seal



Standard, Air Seal



Oversized
(+Custom Oversized XL)



Pre-Burial Double
(+Pre-Burial Single)

Polyguard's Millennial Polymer Vaults Are Game Changers

For over four decades Polyguard & Co. has evolved with advances in technology and manufacturing to become North America's largest manufacturer of polymer burial vaults utilized by thousands of funeral homes and cemeteries across North America. We have set new standards in the burial industry with forty years of polymer vault innovation through engineering, design, and testing.

Millennial Polymer Vaults Provide:

- low cost • high strength to weight ratio • easy transport and storage • better worker safety • on location versatility and performance • non-bio-degradable polymer • environmental safety • moisture protection • cemetery aesthetics protection • definition of the gravesite • water resistance and much more.



THE POLYGUARD ADVANTAGE

Advantages of Millennial Polymer Vaults by Polyguard & Co.

STRONG

Polyguard Burial Vaults are over three times stronger than steel by weight and have far more tensile strength than concrete. The engineered design provides maximum strength to weight ratio assuring maximum ground and equipment load capacity after correct interment procedures are followed.

COLD CONDITIONS

Unlike some polymer vaults, keeping them in a warm place before interment is not required. All Polyguard units are assembled with mastic sealant; some use stainless steel clips.

LIGHTWEIGHT INSTALLATION

Polyguard Burial Vaults are two-piece units that are easily installed by two men with no need for heavy vault-handling equipment, which significantly reduces interment costs.

PROTECTION

Polymers, by nature, are non-biodegradable, non-porous and unaffected by minerals or chemicals found in the soil. These polymers are commonly used in underground water and sewer lines and conduits due to their durable nature and exceptional strength.

DELIVERY

Polyguard is the only polymer vault company utilizing its own trucks for delivery nationwide. Since the trucks are company-owned, the drivers are Polyguard employees.

SEALING OPTIONS

Whether choosing above or below-ground sealing options; for many years, all Polyguard & Co Vaults have utilized mastic sealant for a perfectly durable seal.

SIZES

Polyguard offers a complete line of burial products, including adult, infant, youth, and over-sized burial vaults; as well as a full line of urn vaults.

QUALITY SERVICE

Polyguard Burial Vaults have been a mainstay in the West and Northwest for decades. The reputation for quality and service has been expanded internationally. Polyguard offers you prompt and courteous service. Satisfaction guaranteed.

MULTITUDE OF CHOICES

Polyguard & Co. currently offers 9 different adult burial vaults, six infant or youth vaults, three sizes of infant casket /vault combinations, and eight beautifully molded urn vaults.

COMPETITIVE PRICING

Polyguard offers a wide selection of burial vaults to satisfy all styles, sizes, and budget requirements.

MANUFACTURING EXPERTISE

Our product development team brings expertise in manufacturing, which integrates the design, engineering, and quality control disciplines for superior performance and cost-effectiveness. The molding process entails a physical or chemical blowing agent mixed with the resin in the structural foam process.

The resin is shot into the cavity, but is not completely filled or packed. The blowing agent expands to push the resin to the extremities of the cavities. As the part cools, the internal pressure of the foaming action takes up the internal shrinkage. This precision process reduces sinks over ribs or heavy cross-sections for consistent thickness to each unit.

NESTABLE

Polyguard Burial Vaults nest together, preserving valuable storage space. Ten vaults utilize no more floor space than one or two concrete or steel vaults.

BEAUTIFULLY FINISHED

Our products are aesthetically pleasing and are designed with attractive details and smooth finishes.



PRECISION ENGINEERED

NORTH AMERICA'S LARGEST POLYMER BURIAL VAULT MANUFACTURER



SLATWALL MINIATURE VAULT DISPLAYS

Polyguard Display Elements Provides "Hands-On" Point of Purchase



Slatwall Display: Triton black mini vault; brochures, a full size vault cut-away; and a poster with company logo and color scheme customization.



Slatwall Poster featuring the Triton Grave Liner. Posters are available for all burial products for your slatwall displays and sales room.



Slatwall Display: Hercules black mini vault; brochure; full size vault cut-away; and poster

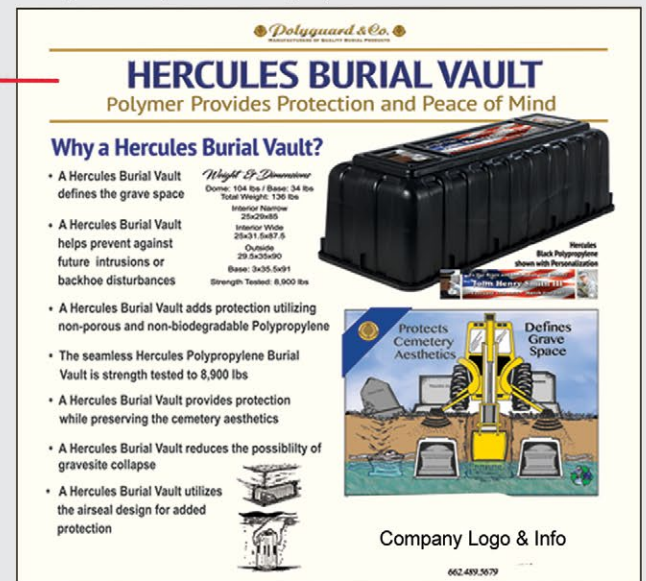

Slatwall poster featuring the black Hercules burial vault. Posters are available for all burial products for your slatwall displays or sales rooms.

Polyguard & Co. supplies our customers with display items for sales rooms and Slatwall display units. Miniature vaults show the structure and design details which families can handle and examine up close. Also provided for your Slatwall display is an actual 'cross-section' sample of an adult burial vault showing ribbing and cross-ribbing. Hardware to hang Slatwall elements is provided for each item. Slatwall panels are not included.

Miniature vaults are available for all adult vaults shown below. In addition to mini display vaults, we provide customized Slatwall posters with your company logo, colors, and other information. Contact us for sales room posters customized for your specific needs.



Triton Graveliner
Black Mini



Maximus Brial Vault
White Mini



Hercules Burial Vault
Black Mini

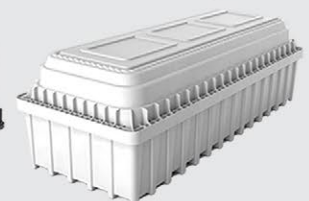

Atlas Burial Vault
Black or White Mini



FINAL EXPRESSION OF LOVE

Vault Personalization Creates a Positive Lasting Memory



Polyguard's Adult Vaults Provide Frames on the Lid for Personalization

The Maximus lid (shown above) and the Atlas II lid structure (see pg. 9) have been designed to accommodate a personalization size of 11x17. Personalization is easily printed with an in-house copy machine, that accommodates 11x17 paper. The printouts can be attached with spray glue or two-sided tape. Wide-format printers which print on sticky-back roll vinyl are ideal for the Hercules Vault personalization (see pg 34). Write sentiments with a "Sharpie" marker right on the surface of the lid (shown above).



TOOLS TO SET AND DISPLAY THE ATLAS AND HERCULES VAULT AT THE CEMETERY

Our vault handling tools are used for quick and easy vault handling at the cemetery, and will be seen during the installation videos at polyguardvaults.com



U-BARS



"U" bars are placed in the grave and spaced as shown in the above photo. The base of the Atlas Vault is placed on top of the "U" bars. "U" bars can be easily made or purchased from Polyguard & Co. Call 800-654-1067

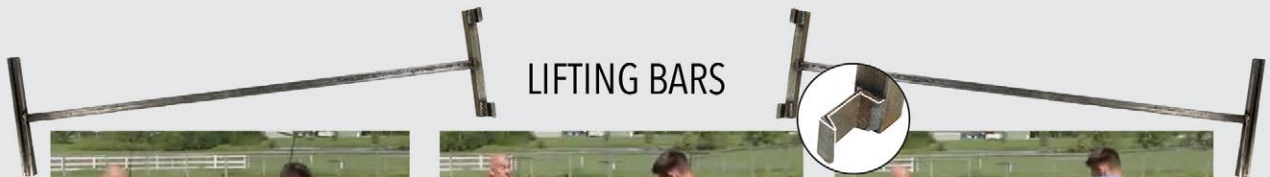

LIFTING BARS



A set of Lifting Bars make easy work of setting the Atlas Vault. Two men can easily set the vault using the lifting bars. You can make your set of lifting bars, or purchase them from Polyguard & Co. Call 800-654-1067

CEMETERY DISPLAY STAND

The Atlas lid is displayed with personalization at the gravesite. The vault lid is placed on the Cemetery Display Stand to show vault personalization at the proper viewing angle and height.

Make your own lid display stand or purchase one from Polyguard & Co. Call 800-654-1067



polyguardvaults.com





BURIAL VAULTS DIRECT TO YOUR LOCATION

Our Delivery Service is Second to None, and Here's Why . . .



Built-in Equipment

Our truck delivery system includes built-in unloading gates, which enable us to place the burial vaults for easy access.

Hassle Free

We ensure that all required paperwork is handled correctly, from freight classes to bills of lading.

No Automated Voices

You will always talk to a real person before, during, and after the delivery if necessary. We want to make sure that your shipment is timely and delivered to the exact location.

Anywhere Shipping

Whether you're in a major metropolitan area or living on the frontier our custom delivery service comes direct to your location.

Friendly Drivers

Experienced courteous drivers are professionals who are representatives of Polyguard & Co.

Our delivery trucks are company-owned and operated for seamless coast to coast delivery.

RMP MOBILE & EQUIPMENT

145 Twin Spruce Industrial Park
Afton, Wyoming 83110

1-800-654-1067

email: polyguard@silverstar.com
www.polyguardvaults.com



“We own and operate our delivery fleet and have the highest standards in service and delivery.”





MISSION STATEMENT

“Our commitment is to design, manufacture,
and sell the highest quality burial products
for use in today’s burial service industry”



— *M. Lee Schwab,*
President, Polyguard & Co.



CONTACT US

Polyguard & Co.
MANUFACTURERS OF QUALITY BURIAL PRODUCTS

Toll Free (800) 654-1067
(307) 885-3883

Website: polyguardvaults.com
(menu bar: 'contact us')

Email: polyguard@silverstar.com

Polyguard & Co.
PO Box 1269
Afton, WY 83110-1269

Polyguard LLC
North America's Largest Polymer
Burial Vault Manufacturer

Copyright © 2024 Polyguard LLC All rights reserved. No part of this publication may be reproduced, distributed, or transmitted in any form or by any means, without the prior permission of the publisher except for uses permitted by copyright law. Contact: Polyguard & Co. 800-654-1067

